

Easy maintenance



Large rear access for easy engine maintenance



Large side cover for easy service access



Water separator with indicator

Safety



Gate Lock System



ROPS Canopy (Option)



Single-structured Swing Pin

Track options



Rubber Tracks / Steel Track / Rubber Pad Options

Easy skimming work



Close distance between Bucket Tooth and Dozer Blade

Durability

Easy fuel refilling



Fuel refill located in a convenient position



► 55V4 Mini Excavator

SPECIFICATIONS:

Dimensions (mm)

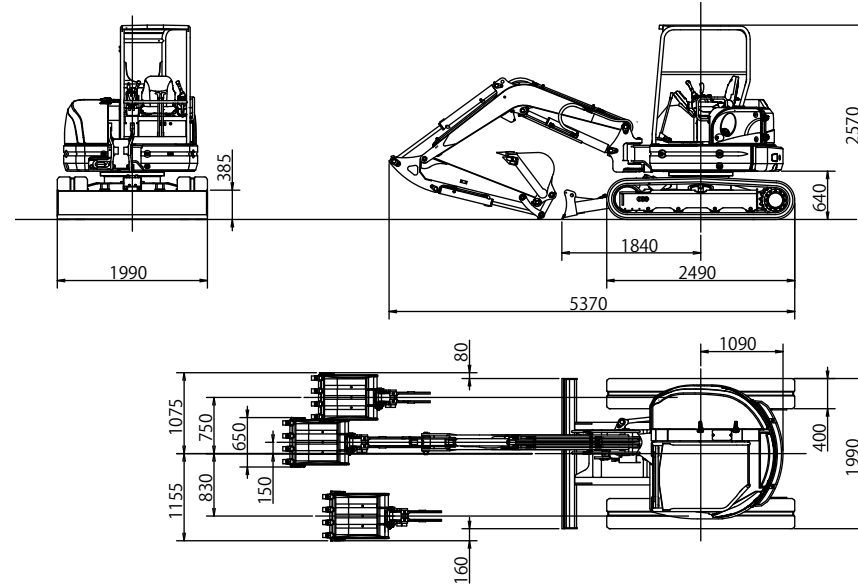

Working Range (mm)

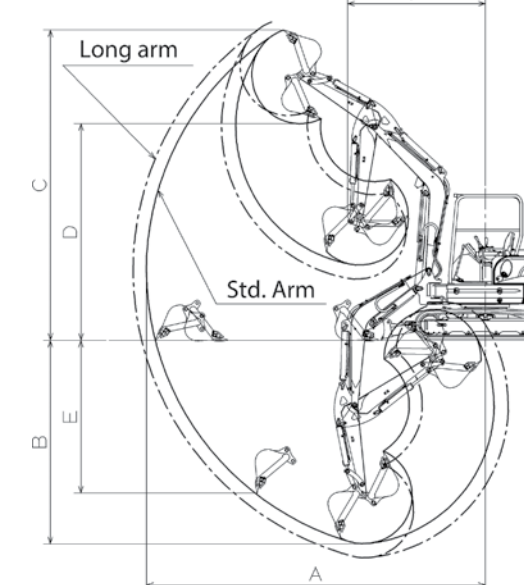

STANDARD:

- ROPS cabin
- Auxiliary piping
- Flashing light
- Removable counter weight
- Rubber tracks

OPTIONS:

- ROPS canopy
- Steel tracks
- Rubber pads
- Short arm
- Air conditioning

	Standard	Option (Short arm)
A. Max. digging radius	6200	5970
B. Max. digging depth	3830	3590
C. Max. digging height	5610	5470
D. Max. dumping height	3960	3820
E. Max. vertical digging depth	2930	2690
F. Min. front turning radius	2460	2420
At right boom swing	2130	2100

Performance		Boom swing system	
Bucket capacity	0.16m ³	Type	Boom offset with hydraulic cylinder
Bucket width (Standard)	650mm	Swing angle (L/R)	80°/50°
Operating weight: 4-Post(Cabin)	5065 (5215) kg	Hydraulic system	
Transportation weight: 4-Post(Cabin)	4990 (5140) kg	Pressure	24.5MPa 250kgf/cm ² /20.6MPa 210kgf/cm ²
Swing speed	9.3min ⁻¹	Pump hydraulic flow	60 L/minx2+ 44.2L/min
Travel speed (low/high)	2.9 / 4.6km/h	Dozer blade	
Gradeability	58% (30°)	Size	1990x385mm
Ground pressure	29kPa (0.30kgf/cm ²)	Lift above ground / Drop below ground	460mm / 430mm
Max bucket digging force	31.0kN (3160kgf)	Max auxiliary flow	
Engine		1st Auxiliary line	60L/min
Model	KUBOTA V2403-DI	2nd Auxiliary line	44L/min (Option)
Rated output (EU version)	32.4kW (44.1PS) /2400min ⁻¹		
Fuel tank capacity	66L		

* Youngman Richardson & Co Ltd reserve the right to change specifications at any time.

PARTS SERVICE:

We are proud of the back-up service we offer to customers. The importance of stocking genuine spare parts for all the equipment we supply is a high company priority.

AUCKLAND HEAD OFFICE
6-10 Parkway Drive,
Mairangi Bay, Auckland
Phone: (+64) 09 443 2436
Fax: (+64) 09 443 2435
Email: sales@yrco.co.nz

SOUTH ISLAND OFFICE
20 Nga Mahi Road,
Sockburn, Christchurch
Phone: (+64) 03 341 6923
Fax: (+64) 03 341 6955
Email: saleschch@yrco.co.nz

PROUD TO BE 100%
NEW ZEALAND
OWNED & OPERATED

YR YOUNGMAN
RICHARDSON
& CO. LTD.



YRCO.CO.NZ



► 55V4 Mini Excavator

A 5.3 ton reduced tail swing mini excavator with exceptional performance



YRCO.CO.NZ

YR YOUNGMAN
RICHARDSON
& CO. LTD.

55V4 Mini Excavator

FEATURES:

- ▶ Newly designed operator's space
- ▶ Reduced tail swing
- ▶ Easy maintenance
- ▶ Low fuel consumption
- ▶ Powerful digging & quick response

Easy Maintenance

- ▶ Large side covers for easy access & maintenance
- ▶ Wide, fully opening engine cover enables ease of maintenance
- ▶ Filters are conveniently located - Includes: Large fuel filter, water separator & tank breather

Durability

- ▶ Easily adjustable pins for longer life
- ▶ Castle nuts for boom & arm joints
- ▶ Single structured swing pin

Safety

- ▶ Gate lock system
- ▶ Neutral engine start
- ▶ ROPS / FOPS cabin or canopy
- ▶ Auto parking brake in swing & traction motors



High Digging Power & Quick Response

Digging force increased by 10%
Highly responsive 3-pump system

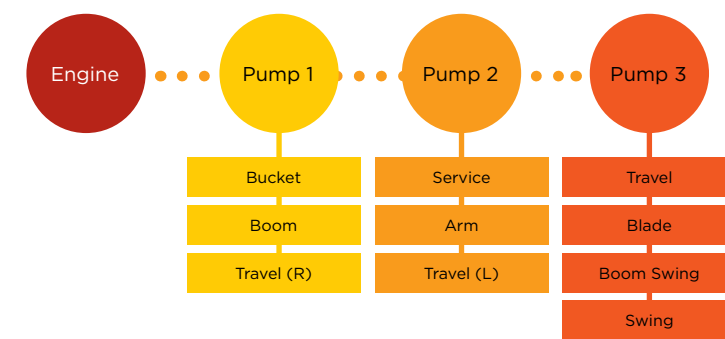

Selectable Working Mode

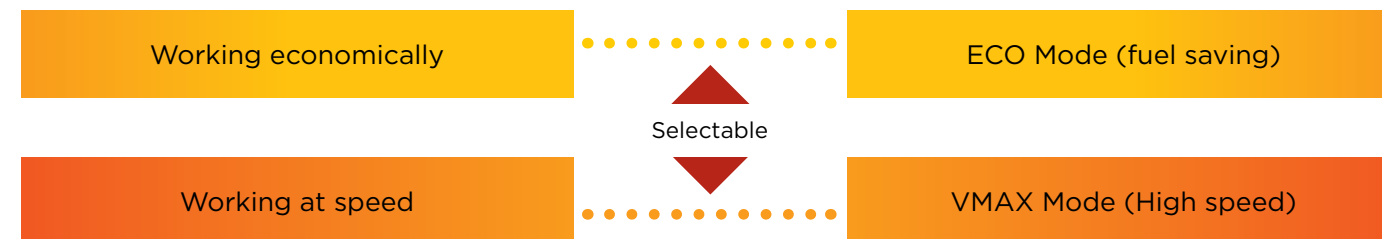

Lower Fuel Consumption

Max. 24% fuel saving*

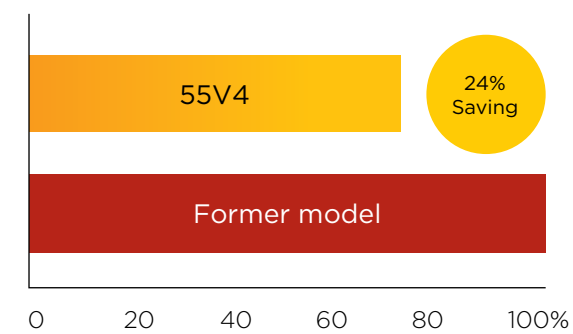

PRODUCT RANGE:



Comfortable Operating Room



Centralised switches - includes key start, throttle dial, auto idle & eco mode



Easily visible monitor - includes travel speed, auto idle, eco mode, hour meter & engine management



Full suspension seat - c/w retracting seat belt



Control Lever with proportional switch for auxiliary hydraulic



Traction foot pedals (fold away)